

P20058, P20075 P20100, P20125

Industrial Flatwork Ironers



Architectural/Mechanical Product Specifications

888.560.4925 fax 920.231.4220 2500 State Rd 44

www.onepressironer.com Oshkosh, WI 54904

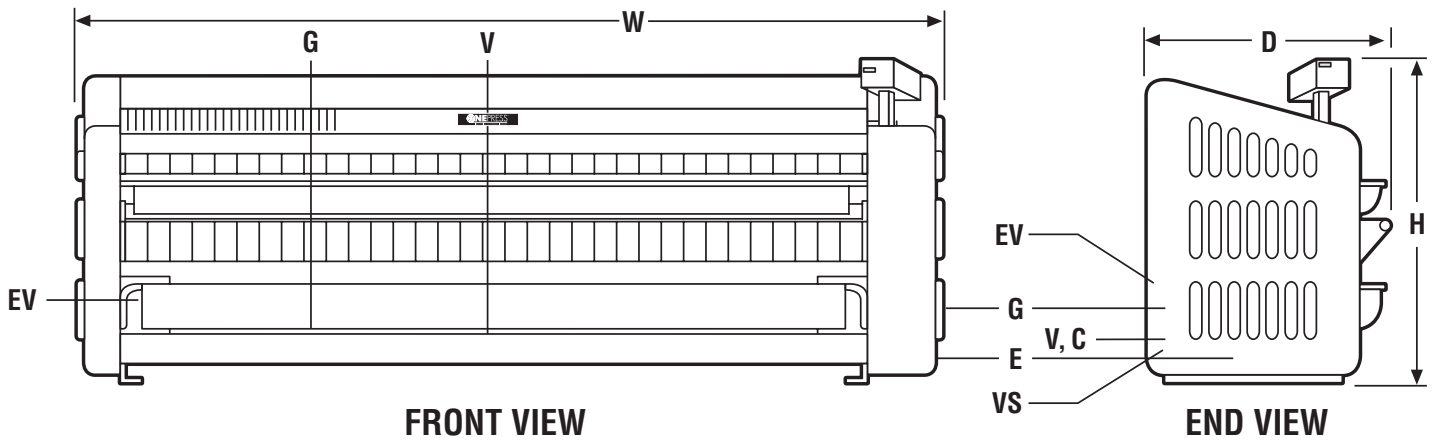

*Specifications subject to change without notice.

P20058, P20075, P20100, P20125 Product Technical Specifications

	GAS/ELECTRIC				STEAM	
	P20058	P20075	P20100	P20125	P20075	P20125
Cylinder Diameter	20.1 in. (510 mm.)	20.1 in. (510 mm.)	20.1 in. (510 mm.)	20.1 in. (510 mm.)	20.1 in. (510 mm.)	20.1 in. (510 mm.)
Usable Cylinder Length	58.3 in. (1480 mm.)	74.8 in. (1900 mm.)	99.6 in. (2530 mm.)	124.6 in. (3165 mm.)	74.8 in. (1900 mm.)	124.6 in. (3165 mm.)
Finishing Speed	3-21 ft./min. (1-6.5 m./min.)	3-21 ft./min. (1-6.5 m./min.)	3-21 ft./min. (1-6.5 m./min.)	3-21 ft./min. (1-6.5 m./min.)	3-21 ft./min. (1-6.5 m./min.)	3-21 ft./min. (1-6.5 m./min.)
SHIPPING WEIGHT:						
W	2,447 lbs. (1110 kg.)	2,976 lbs. (1350 kg.)	3,571 lbs. (1620 kg.)	4,001 lbs. (1815 kg.)	3,538 lbs. (1605 kg.)	5,269 lbs. (2390 kg.)
F	2,646 lbs. (1200 kg.)	3,219 lbs. (1460 kg.)	3,902 lbs. (1770 kg.)	4,409 lbs. (2000 kg.)	3,792 lbs. (1720 lbs.)	5,666 lbs. (2570 kg.)
NET WEIGHT:						
W	1,962 lbs. (890 kg.)	2,425 lbs. (1100 kg.)	2,921 lbs. (1325 kg.)	3,263 lbs. (1480 kg.)	2,987 lbs. (1355 kg.)	4,530 lbs. (2055 kg.)
F	2,138 lbs. (970 kg.)	2,634 lbs. (1195 kg.)	3,197 lbs. (1450 kg.)	3,616 lbs. (1640 kg.)	3,197 lbs. (1450 kg.)	4,883 lbs. (2215 kg.)
DIMENSIONS:						
Height (H)	55.9 in. (1420 mm.)	55.9 in. (1420 mm.)	55.9 in. (1420 mm.)	55.9 in. (1420 mm.)	55.9 in. (1420 mm.)	55.9 in. (1420 mm.)
Width (W)	85.4 in. (2170 mm.)	102.2 in. (2595 mm.)	127 in. (3225 mm.)	152 in. (3860 mm.)	104.9 in. (2665 mm.)	154.7 in. (3930 mm.)
Depth: (D)	45.8 in. (1164 mm.)	45.8 in. (1164 mm.)	45.8 in. (1164 mm.)	45.8 in. (1164 mm.)	45.8 in. (1164 mm.)	45.8 in. (1164 mm.)
MINIMUM CLEARANCES:						
Rear	20 in. (50 cm.)	20 in. (50 cm.)	20 in. (50 cm.)	20 in. (50 cm.)	20 in. (50 cm.)	20 in. (50 cm.)
Sides	20 in. (50 cm.)	20 in. (50 cm.)	20 in. (50 cm.)	20 in. (50 cm.)	20 in. (50 cm.)	20 in. (50 cm.)
Front	48 in. (122 cm.)	48 in. (122 cm.)	48 in. (122 cm.)	48 in. (122 cm.)	48 in. (122 cm.)	48 in. (122 cm.)
Exhaust Diameter (EV)	5.1 in. (130 mm.)	5.1 in. (130 mm.)	5.1 in. (130 mm.)	5.1 in. (130 mm.)	5.1 in. (130 mm.)	5.1 in. (130 mm.)
Exhaust Air Flow	497 cfm (844 m3/h.)	497 cfm (844 m3/h.)	497 cfm (844 m3/h.)	497 cfm (844 m3/h.)	497 cfm (844 m3/h.)	497 cfm (844 m3/h.)
Motor Power	1.48 Hp (1.48 CV)	1.48 Hp (1.48 CV)	1.48 Hp (1.48 CV)	1.48 Hp (1.48 CV)	1.48 Hp (1.48 CV)	1.48 Hp (1.48 CV)
CIRCUIT PROTECTION:						
Electrical 208-240/60/3	100 Amps	125 Amps	160 Amps	200 Amps	-	-
Gas 208-240/60/3	13 Amps	13 Amps	13 Amps	13 Amps	-	-
Steam 208-240/60/3	-	-	-	-	13 Amps	13 Amps
Full Load	11.3 Amps	11.3 Amps	11.3 Amps	11.3 Amps	11.3 Amps	11.3 Amps
Electric Heating (E)	28 Kw	35.5 Kw	47 Kw	60 Kw	-	-
Gas Heating	111,000 BTU/h (28,000Kcal/h)	143,000 BTU/h (35,500Kcal/h)	186,500 BTU/h (47,000Kcal/h)	238,000 BTU/h (60,000Kcal/h)	-	-
Gas Inlet Diameter (G)	0.75 in. (19 mm.)	0.75 in. (19 mm.)	0.75 in. (19 mm.)	0.75 in. (19 mm.)	-	-
Gas Supply:						
Natural	7 (± 1) in.	7 (± 1) in.	7 (± 1) in.	7 (± 1) in.	-	-
Propane	11 (± 0.3) in.	11 (± 0.3) in.	11 (± 0.3) in.	11 (± 0.3) in.	-	-
Steam Heating	-	-	-	-	166,500 BTU/h (42,000Kcal/h)	277,750 BTU/h (70,000Kcal/h)
Steam Inlet Diameter (V)	-	-	-	-	1 in. (25.4 mm.)	1 in. (25.4 mm.)
Steam Consumption	-	-	-	-	146 lbs/h (66 kg/h)	243 lbs/h (110 kg/h)
Steam Pressure	-	-	-	-	116 psi (8 bar)	116 psi (8 bar)
BHP Consumption	-	-	-	-	4.97 BHP	8.3 BHP
Condensate Outlet Dia. (C)	-	-	-	-	0.75 in. (19 mm.)	0.75 in. (19 mm.)
Safety Valve Discharge Dia.(VS)	-	-	-	-	0.5 in. (12.7 mm.)	0.5 in. (12.7 mm.)

*International Voltages Available

Specifications subject to change without notice.



888.560.4925 fax 920.231.4220 2500 State Rd 44 Oshkosh, WI 54904 www.onepressironer.com